

# G 252 F / HP 8



**MOTORE A BENZINA ORIZZONTALE - 4 TEMPI**  
**GASOLINE ENGINE HORIZONTAL - 4 STROKE**



**LONCIN**

## MOTORE / ENGINE

## G 252 F HP 8

Monocilindrico, raffreddamento ad aria 4 tempi / <i>Single cylinder, forced air cooled, 4 - stroke</i>	
Alesaggio corsa / <i>Bore Stroke</i>	75 x 57 mm
Cilindrata / <i>Displacement</i>	252 cc
Potenza nominale / <i>Rated power</i>	5,2 Kw
Coppia max. / <i>Max. torque</i>	15,2 NM - 2800 rpm
Giri motore / <i>Engine speed</i>	3600 r.p.m.
Carburante / <i>Fuel</i>	Benzina / <i>Gasoline</i>
Capacità Serbatoio / <i>Fuel Capacity (Lt)</i>	4 Lt
Capacità Serbatoio Olio / <i>Fuel Oil Capacity (Lt)</i>	0,7 Lt
Avviamento Standard / <i>Starting System</i>	Manuale / <i>Recoil</i>
Rumorosità / <i>Noise ≤7m dB (A)</i>	70
Dimensioni / <i>Dimension</i>	365 x 285 x 370
Peso a secco / <i>Dry Weight</i>	16,5 Kg

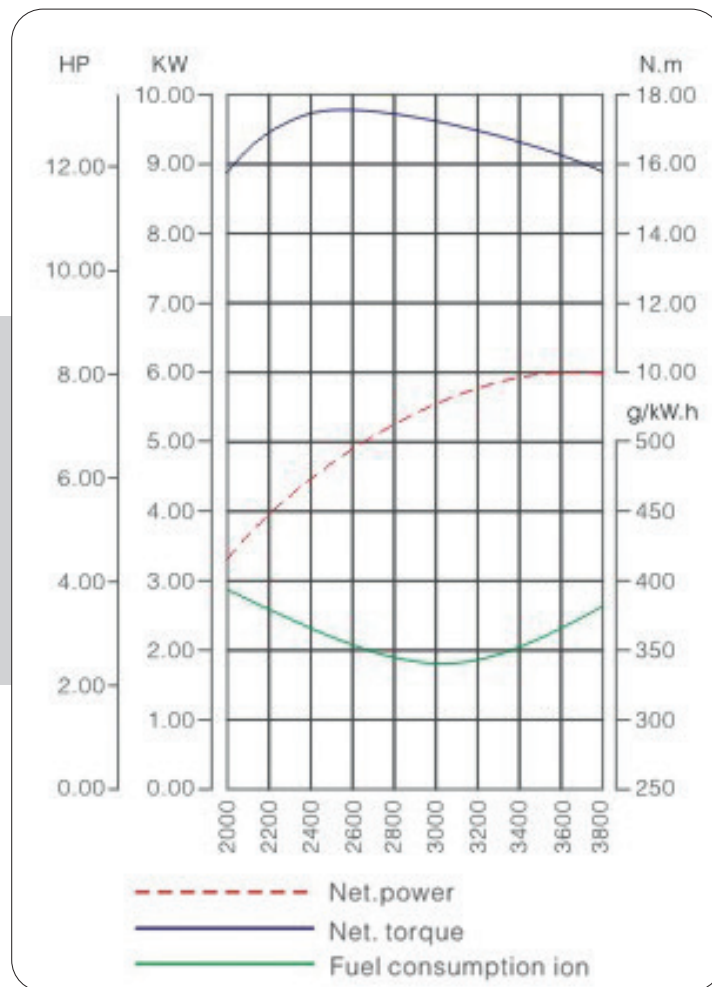

## VERSIONE / VERSIONS

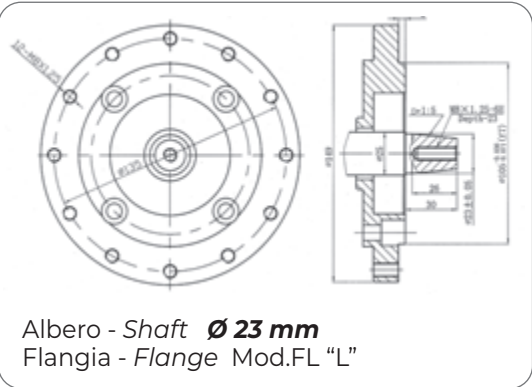

### G 252 F-L

- Albero Conico
- Avviamento Manuale
- Filtro Aria bagno olio
  
- Conical Shaft
- Manual Start
- Oil Bath Air Filter

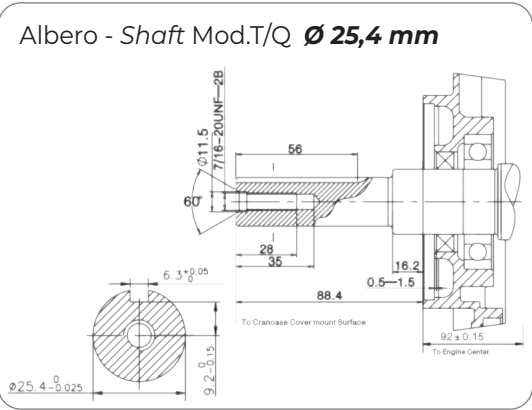

### G 252 F-T/Q

- Albero Cilindrico
- Avviamento Manuale
- Filtro Aria a secco
  
- Cylindrical Shaft
- Manual Start
- Dry air filter