

APPLICAZIONI

Elettropompe sommerse inox per drenaggio, con girante immersa tipo Vortex arretrata in acciaio inox, adatte per svuotamento di fosse di decantazione e per pompaggio di acque luride ad uso domestico e civile.

APPLICATION

Submersible drainage stainless steel water pumps, with stainless steel plunged back impeller Vortex type.

Able to drain decanting cesspools and to pump waste water for domestic and civil purposes.

LIMITI D'IMPIEGO

- Temperatura liquido fino a 35°C (per un uso domestico secondo EN 60335-2-41)
- Temperatura max. liquido: 35°C (per altri impieghi)
- Massima profondità d'immersione 10 mt.
- Passaggio solidi Ø 50 mm
- Livello min. d'aspirazione 70 mm
- Servizio continuo

MOTORE

- Monofase 230V-50Hz (con galleggiante)
- Trifase 400V-50Hz
- Doppia camera con motore in bagno d'olio per raffreddamento e lubrificazione cuscinetti
- Condensatore permanente inserito
- Isolamento Classe F
- Protezione IP 68

MATERIALI

- | | |
|-------------------------------------|-----------------------------|
| - Maniglia | Acciaio Inox AISI 304+Nylon |
| - Cassa motore | Acciaio Inox AISI 304 |
| - Corpo pompa | Ghisa |
| - Girante | Acciaio Inox AISI 304 |
| - Griglia aspirazione | Acciaio Inox AISI 304 |
| - Albero motore | Acciaio Inox AISI 304 |
| - Tenuta meccanica in camera d'olio | Silicio/Silicio/NBR |

OPERATING CONDITIONS

- Liquid temperature up to 35°C (for home use according to EN 60335-2-41)
- Temperature max. liquid: 35°C (for other uses)
- Maximum immersion depth 10 mt.
- Grain size inlet Ø 50 mm
- Min. suction level 70 mm
- Continuous duty

MOTOR

- Single-phase 230V-50Hz (with floater)
- Three-phase 400V-50Hz
- Dual chamber with oil bath motor for cooling and bearing lubrication
- Permanent split capacitor
- Insulation Class F
- Protection IP 68

MATERIALS

- | | |
|----------------------------------|--------------------------------|
| - Handle | Stainless Steel AISI 304+Nylon |
| - Motor casing | Stainless Steel AISI 304 |
| - Pump body | Cast Iron |
| - Impeller | Stainless Steel AISI 304 |
| - Suction grid | Stainless Steel AISI 304 |
| - Shaft with rotor | Stainless Steel AISI 304 |
| - Mechanical seal in oil chamber | Silicon/Silicon/NBR |



GIRANTE - IMPELLER

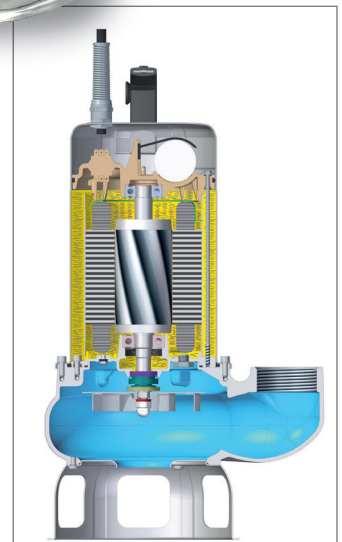

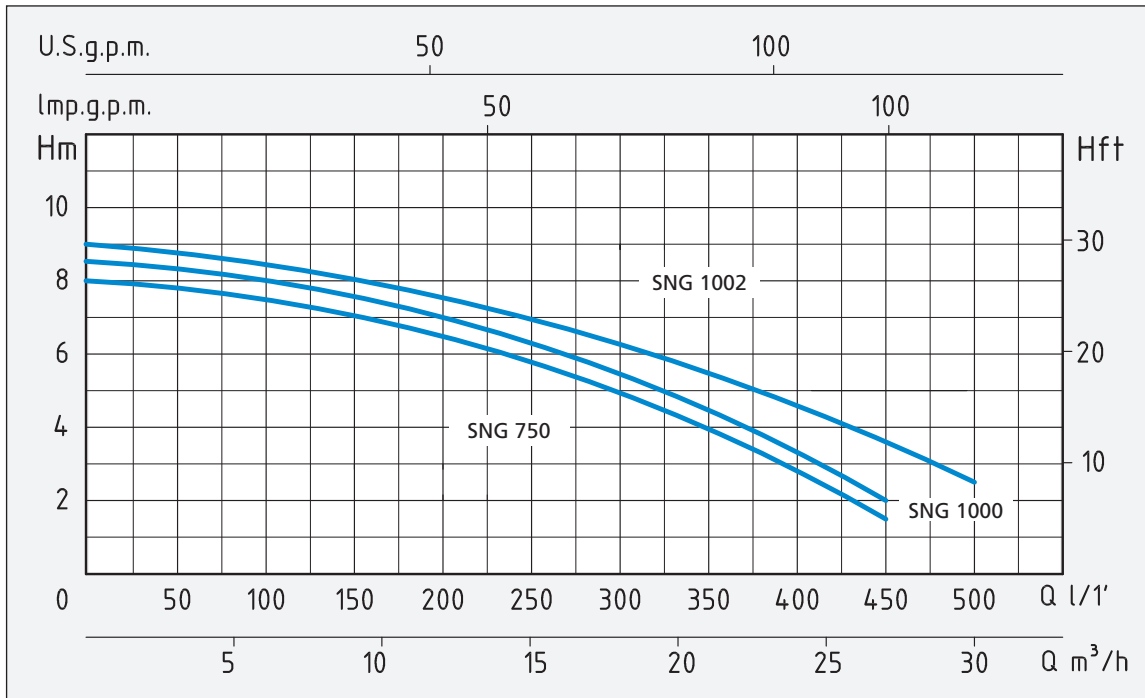

TIPO TYPE	POTENZA NOMINALE NOMINAL POWER		POTENZA ASSORBITA INPUT POWER	AMPERE	Q = PORTATA - CAPACITY													
	P2		P1		Prevalenza manometrica totale in m.C.A. - Total head in meters w.c.													
Monofase Single-phase	HP	kW	kW	Monofase Single-phase	m³/h	1,8	3,6	5,4	7,2	9	12	15	18	21	24	27		
	SNG 750-VS	0,75	0,55		1	4,4	lt/1'	30	60	90	120	150	200	250	300	350	400	450
SNG 1000-VS	1	0,75	1,2	5,3	H (m)	8	7,8	7,5	7,3	7	6,5	5,8	5	4	2,8	1,5		
SNG 1002-VS	1,1	0,8	1,3	6		8,5	8,2	8	7,8	7,5	7	6,5	5,5	4,5	3,5	2		
						9	8,7	8,5	8,3	8	7,5	7	6,5	5,5	4,5	3,5		

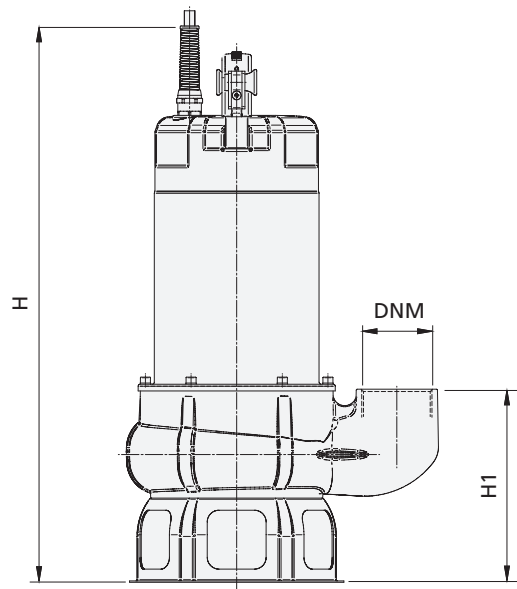
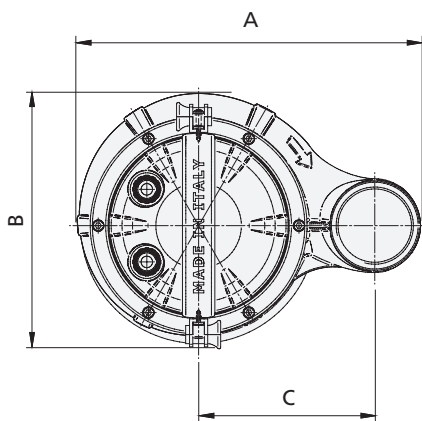

TIPO TYPE	DIMENSIONI mm - DIMENSIONS mm							DIMENSIONI DIMENSIONS mm			PESO WEIGHT Kg
	A	B	C	H	H1	DNM	CAVO - CABLE	P	L	H	
Monofase Single-phase											
SNG 750-VS	234	174	111,5	445	156	1" 1/2	10 mt H07RNF	237	287	524	12
SNG 1000-VS	234	174	111,5	445	156	1" 1/2	10 mt H07RNF	237	287	524	12,5
SNG 1002-VS	257	182	129	457	167,5	2"	10 mt H07RNF	237	287	524	13

APPLICAZIONI

Elettropompe sommerse inox per drenaggio, con girante immersa tipo Vortex arretrata in acciaio inox, adatte per svuotamento di fosse di decantazione e per pompaggio di acque luride ad uso domestico e civile.

APPLICATION

Submersible drainage stainless steel water pumps, with stainless steel plunged back impeller Vortex type.

Able to drain decanting cesspools and to pump waste water for domestic and civil purposes.

LIMITI D'IMPIEGO

- Temperatura liquido fino a 35°C (per un uso domestico secondo EN 60335-2-41)
- Temperatura max. liquido: 35°C (per altri impieghi)
- Massima profondità d'immersione 10 mt.
- Passaggio solidi Ø 50 mm
- Livello min. d'aspirazione 70 mm
- Servizio continuo

MOTORE

- Monofase 230V-50Hz (con galleggiante)
- Trifase 400V-50Hz
- Doppia camera con motore in bagno d'olio per raffreddamento e lubrificazione cuscinetti
- Condensatore permanente inserito
- Isolamento Classe F
- Protezione IP 68

MATERIALI

- | | |
|-------------------------------------|-----------------------------|
| - Maniglia | Acciaio Inox AISI 304+Nylon |
| - Cassa motore | Acciaio Inox AISI 304 |
| - Corpo pompa | Ghisa |
| - Girante | Acciaio Inox AISI 304 |
| - Griglia aspirazione | Acciaio Inox AISI 304 |
| - Albero motore | Acciaio Inox AISI 304 |
| - Tenuta meccanica in camera d'olio | Silicio/Silicio/NBR |

OPERATING CONDITIONS

- Liquid temperature up to 35°C (for home use according to EN 60335-2-41)
- Temperature max. liquid: 35°C (for other uses)
- Maximum immersion depth 10 mt.
- Grain size inlet Ø 50 mm
- Min. suction level 70 mm
- Continuous duty

MOTOR

- Single-phase 230V-50Hz (with floater)
- Three-phase 400V-50Hz
- Dual chamber with oil bath motor for cooling and bearing lubrication
- Permanent split capacitor
- Insulation Class F
- Protection IP 68

MATERIALS

- | | |
|----------------------------------|--------------------------------|
| - Handle | Stainless Steel AISI 304+Nylon |
| - Motor casing | Stainless Steel AISI 304 |
| - Pump body | Cast Iron |
| - Impeller | Stainless Steel AISI 304 |
| - Suction grid | Stainless Steel AISI 304 |
| - Shaft with rotor | Stainless Steel AISI 304 |
| - Mechanical seal in oil chamber | Silicon/Silicon/NBR |



GIRANTE - IMPELLER

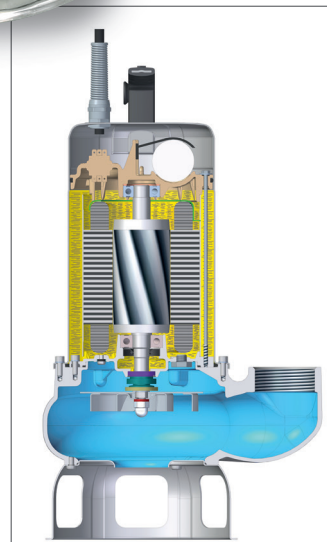

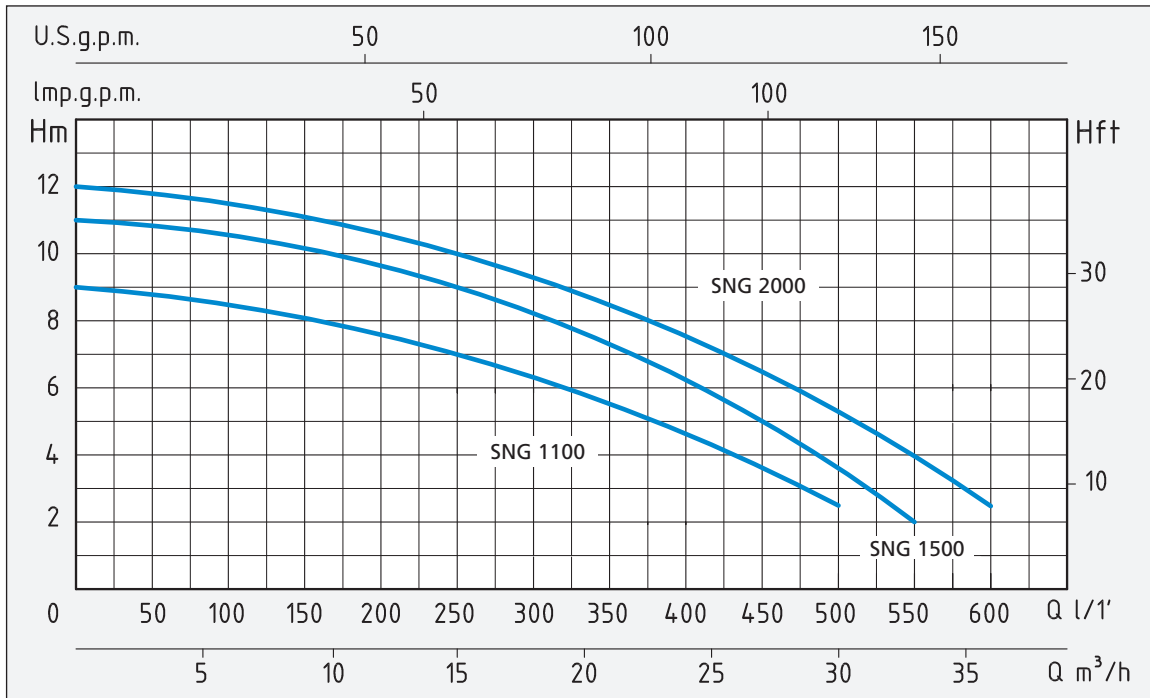

TIPO TYPE		POTENZA NOMINALE NOMINAL POWER		POTENZA ASSORBITA INPUT POWER	AMPERE		Q = PORTATA - CAPACITY												
Monofase Single-phase	Trifase Three-phase	P2		P1	Monofase Single-phase	Trifase Three-phase	Prevalenza manometrica totale in m.C.A. - Total head in meters w.c.												
		HP	KW	KW			m³/h	1,8	3,6	5,4	7,2	9	12	15	18	24	30	36	
SNG 1100-VS		1,1	0,8	1,3	6		9	8,7	8,5	8,3	8	7,5	7	6,5	4,5	2,5			
SNG 1500-VS	SNG 1500-TV	1,5	1,1	1,5	7	2,7	11	10,7	10,5	10,3	10	9,5	9	8,5	6,5	3,5			
SNG 2000-VS	SNG 2000-TV	2	1,5	1,85	8,2	3,7	12	11,7	11,5	11,3	11	10,5	10	9,5	7,5	5,5	2,5		

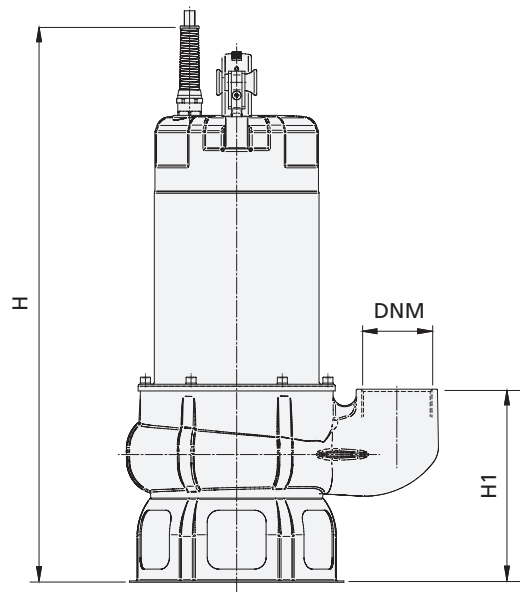
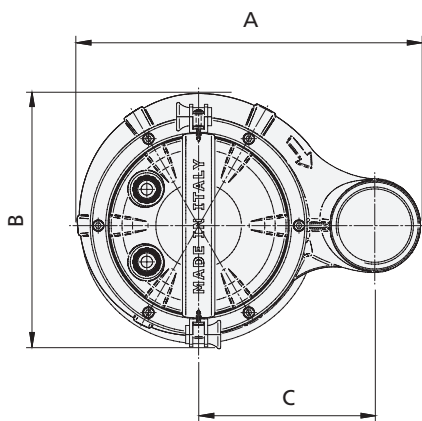

TIPO TYPE		DIMENSIONI mm - DIMENSIONS mm							DIMENSIONI DIMENSIONS mm			PESO WEIGHT
Monofase Single-phase	Trifase Three-phase	A	B	C	H	H1	DNM	CAVO - CABLE	P	L	H	Kg
SNG 1100-VS		265	197	136	472	164	2"	10 mt H07RNF	237	287	524	14,5
SNG 1500-VS	SNG 1500-TV	265	197	136	472	164	2"	10 mt H07RNF	237	287	524	15,5
SNG 2000-VS	SNG 2000-TV	265	197	136	472	164	2"	10 mt H07RNF	237	287	524	16